



# Action Tape 3014

## COATING 40

Product Information 01.2020

1/2

### Action Tape 3014

This product is a double sided acrylic based adhesive tapes, which is especially designed for the bonding of high and medium energy substrates. This tape is capable of absorbing the differing thermal expansions of the two different materials. This type maintains a high impact resistance even at temperatures below 0° C. This 30-series has a very high initial tack due to CCP's coating 40 and has a very good plasticizer resistance. Advantage of the excellent adaptability is that thin or textured surfaces can be bonded full surface and tension free.

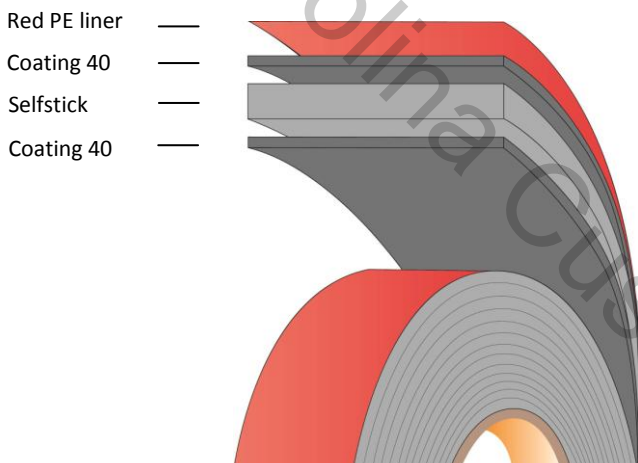

Thickness:	1,6 mm (0.062 inch) ± 10%
Core:	Conformable acrylic
Adhesive:	Acrylic coating 40
Density:	840kg/m <sup>3</sup> (52lb/ft <sup>3</sup> )
Color:	Light Gray
Liner:	Red PE liner or white paper liner
Solvent Resistance:	Excellent
UV Resistance:	Excellent
Temperature Resistance:	
Minimum	-40°C (-40°F)
Short term	160°C(320°F)
Long term	100°C(212°F)

90° Peel Adhesion	N/10mm (lb/in)	41 (23)		ASTM D3330
Dynamic Shear Strength	kPa (lb/in <sup>2</sup> )	540 (78)		ASTM D-1002
Normal Tensile	kPa (lb/in <sup>2</sup> )	540 (78)		ASTM D-897
Static Shear Strength	Grams Weight that ½ square inch will hold for 10,000 minutes (7 days)	22°C (72°F) 66°C (150°F) 93°C (200°F) 121°C (250°F) 177°C (350°F)	1000 500 500	ASTM 3654

Suitable for:

- various high and medium surface energy plastics, glass, steel, aluminum, ceramics \*

Available sizes:

- jumbo: 900mm x 165 meters (core 3")
- log: 900mm x 16,5/33 meters (core 3")
- slit roll: 4 – 250mm x 16,5/33 meters (core 3")
- spool roll: 5 – 25mm x max 700 meters (core 6")



# Action Tape 3014

## COATING 40

Product Information 01.2020

2/2

### Application Guidelines

Every good bond starts with proper surface preparation. This preparation consists of several steps, such as cleaning, abrading, applying pressure, the use of a primer and the right working environment. It is important to ensure your work area to be clean and free from dust and contaminants.

A minimum temperature of 15 °C is required.

### Cleaning

To clean your light and medium contaminated substrates, CCP offers the CCP Action Clean or an isopropanol/alcohol solution (IPA) is acceptable. When cleaning your substrate, a tear free, light colored paper towel is required. Wipe the substrate in one direction using the one cloth method (one cloth with cleaner) or a two cloth method (one cloth with cleaner and one dry cloth to follow) is acceptable if you are short on time. Repeat these steps until your cloth is clean and free of any contaminants. For heavily contaminated substrates, use a cleaning agent such as MEK, Heptan or Acetone. These cleaning agents may leave a residue, which would have to be removed using the IPA cleaner.

### Abrasion

When bonding to raw aluminum, abrading of the surface is a must. The oils used in the waltzing of the aluminum are pressed into the pores of the material. To remove these oils, that will influence the bond, we recommend using the CCP Action Pads. These abrasive pads ensure the proper level of abrasion without damaging your substrates. Besides raw aluminum, abrading is a method utilized to help improve your bond. After the abrasion process is completed, remove any residue using an IPA cleaner following the methods mentioned above.

### Primer

The use of a primer is recommended when bonding to some low surface energy substrates. Examples include, different types of polymers, powder coated metals, or porous materials such as wood, cork, stone or concrete. Primers are also used to help speed up your production process. The CCP Action Tape line can take up to 72 hours to reach its end-strength. The use of a primer ensures the end-strength will be achieved within 20 minutes. CCP offers two primers; the primer 33 and the primer 101. Determining which one of these primers is suitable for your application ultimately depends on the substrates and environmental influences. Your CCP technical support will gladly advise you which primer to use.

### Pressure

CCP Action Tapes are pressure sensitive adhesives. Therefore, a minimum amount of pressure is required on the bond line to ensure the maximum adhesion to your substrates. This pressure should be applied in a rolling fashion. A hand roller or mechanical presser are the preferred methods. The pressure on the bond line must be a minimum of at least 10N/cm<sup>2</sup>.

### Storage & Shelf life

Please make sure that the tape is stored in its original packaging, in a dry place and at a preferable temperature between 4 °C and 38 °C. When the tape is stored under the proper conditions, the tape has a shelf life of 18 months.

### \*Important Information

All technical data in this product data sheet are based on CCP's experience and external testing institutes. These values are representative of the overall performance. These data sheets are NOT to be used for specification purposes or for your own specific application. It is your responsibility to test whether the tape is suitable for your application or project. CCP will NOT be held liable for any information provided on this data sheet.

You must follow the rules and regulations that are applicable in the state, county or country where the CCP product(s) are being used. If you have any questions regarding the use of the CCP Action Tape acrylic foam tapes, please contact our technical sales team. For questions on the standard warranty, please review our standard delivery terms and conditions. For all other warranties, please review all documents that should have been agreed to in writing prior to the sale between CCP and the customer. Action Tape is a brand name of CCP.