



Action Tape 1010

Direct Foam

Product Information 01.2021

Action Tape 1010

This product is a double sided high performance acrylic based adhesive tape, which is especially designed for a variety of materials with high surface energy like glass, aluminum and steel. This tape is capable of absorbing the different thermal expansions of two materials. Because of their high density, this tape offers, when used on the right high surface energy substrates, the strongest available bond. This acrylic foam tape has a very high temperature resistance. In combination with a primer, this Action Tape family guarantees excellent adhesion performance even on low surface energy substrates.

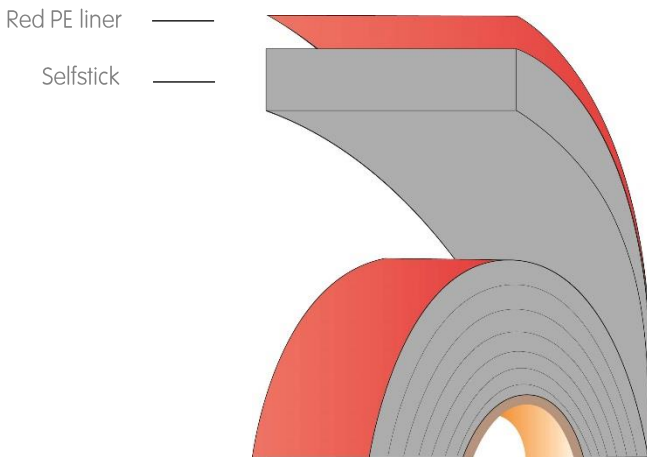

Thickness:	1,6 mm (0.062 inch) ±10%
Core:	Closed cell acrylic
Adhesive:	Closed cell acrylic
Density:	880 kg/m ³ (54lb/ft ³)
Color:	Gray
Liner:	Red PE liner or Siliconised Paper liner
Temperature Resistance:	
Minimum	-40°C (-40°F)
Short term	190°C (374°F)
Long term	120°C (248°F)

90° Peel Adhesion	N/10mm (lb/in)	38 (22)	ASTM D3330
Dynamic Shear Strength	kPa (lb/in ²)	540 (78)	ASTM D-1002
Normal Tensile	kPa (lb/in ²)	540 (78)	ASTM D-897
Static Shear Strength	g/312mm ² > 10,000 min. (7 days)	22°C (72°F) 1500 66°C (150°F) 750 93°C (200°F) 750 121°C (250°F) 750 177°C (350°F) 750	ASTM 3654

Suitable for:

- glass, glass/epoxy, stainless steel, galvanized steel, anodized steel, coated aluminum*

Available sizes:

- jumbo: 900mm x 165 m (76,2mm core)
- log: 900mm x 16,5/33 m (76,2mm core)
- slit roll: 4 – 250mm x 16,5/33 m (76,2mm core)
- spool roll: 5 – 25mm x max 700 m (152,4mm core)





Action Tape 1010

Direct Foam

Product Information 01.2021

2/2

Surface	Tape bonding is one of the most variable and easy technologies mating substrates. Especially for assemblies made of different substrates having different thermal expansion rates. Bonding is an easy method for a long term joint. CCP tapes allow a high variation in such substrates as all are available in different thicknesses. To ensure proper performance of such bonded parts, see the following recommendations.
Design	A proper tape bond design means avoiding cleavage and peel forces. Design leading to pure shear and tensile loads have to be preferred to utilize full CCP Action Tape performance.
Surface Preparation	All bonding processes require proper surface preparation and cleaning. This will enable CCP Action Tapes to get in direct contact with the surface creating full adhesion force. CCP Action Clean Dirt & Dust will remove most (polar) contaminations such as fingerprints and light oil. CCP Action Clean Oil & Grease is used for more non-polar contaminations as grease mold release agents. Check suitable cleaner with surface test inks. Use lint-free tissues for such operations.
Surface Modification	If simple cleaning cannot achieve appropriate adhesion forces the following surface modifications can be used. For larger scale process operations, the use of e.g. flame activation can be used. On smaller scale repair operations, the use of CCP Action Prime or CCP Action Activate might be a solution. CCP Action Prime 10 (UV) is used for plastics or similar coatings which have a low surface energy. For glass, CCP Action Prime 201 is used when exposed to humid environments. CCP Action Activate 301 is a solution used for a variety of car paints. All primer/activators should only be used on the area for bonding. Excess material needs to be cleaned immediately. For mill finished aluminum or stainless steel, CCP Action Pads can be used to create light abrasions followed up by cleaning with CCP Action Clean Dirt & Dust.
Temperature	After proper surface preparation, CCP Action Tapes should be applied at a temperature level above 65° F (18° C). For temperatures below this but above 32° F, use CCP low temperature Action Tapes.
Pressure	Ensure immediate part assembly after linear removal. Pressure should be applied in rolling fashion at approximately 10N/cm ² . Recommended roller speed at 24 in/s (10 mm/s). Higher v speeds might require higher pressure or control with surface pressure films. CCP Action Tapes reach full strength after 24 hours at ambient temperature. Higher temperatures can accelerate strength development.
Storage & Shelf Life	Store CCP Action Tapes between 40°-95° F (5°-35° C). Humid conditions should be avoided. For products with non-siliconized liners, shelf life is 24 months; products with siliconized liners and CCP splice/tapping have a shelf life of 12 months.
Disclaimer	All technical data in this data sheet are based on CCP's experience and external testing. These values are representative for the overall performance. These data sheets are NOT to be used for specification purposes or for your own specific application. It is your responsibility to test whether the tape is suitable for your application or project. CCP will not be held liable for any information provided on this data sheet. Please follow the rules and regulations that are applicable in the state, county or country where CCP products are being used. If you have any questions regarding the use of the CCP Action Tape acrylic foam tapes, please contact your sales rep. Please review all documents that should have been agreed to in writing prior to the sale between CCP and the customer. Action Tape is a brand name of CCP.